

Scheda tecnica UD CS 6.3xL







Tabella Tecnica Autoformante INOX per ferro

Trazione  15.000 N	 Spessore [mm]	 Preforo [mm]	Sfilamento ferro 
Taglio  12.000 N			
N=Newton 1N=kgf 0.1019716	3 4 5 6	5 5.35 5.60 5.80	6.580 N 9.080 N 10.500 N 11.400 N

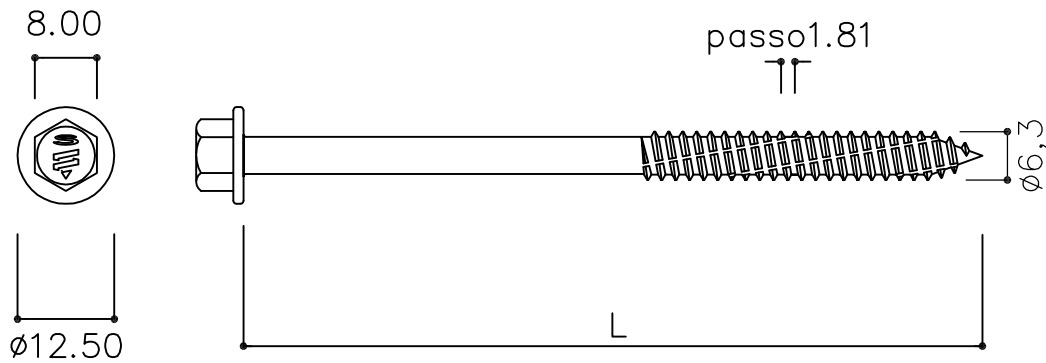
Si consiglia l'utilizzo di avvitatori dotati di limitatori di profondità e velocità sotto carico di 1000/1500 giri

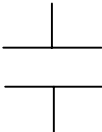
MATERIALE: Acciaio INOX AISI 304

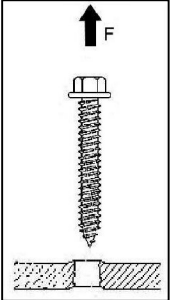
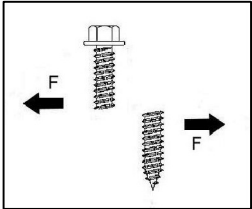
SCALA: 1:1

TRATTAMENTO:

FIRMA: F. Paxia

RIVESTIMENTO: Lubrificante di Zincatura

DATA: 14/03/2011



UFFICIO TECNICO
Via dell'Industria,12
20032 Cormano - Mi
TEL. 02/6192097

DESCRIZIONE: UD CS 6,3 X L

DESCRIZIONE DETTAGLIATA

Vite autoformante INOX per ferro