

Scheda tecnica UXW2 6.5 x L



Tabella Tecnica Autoperforante Inox BIMETAL

<p>Trazione</p>  <p>15.000 N</p>	 <p>Spessore [mm]</p>	<p>Sfilamento ferro</p> 	<p>Sfilamento legno abete</p> 
<p>Taglio</p>  <p>12.000 N</p>		<p>0.6 1 2</p>	<p>Profondità 30 [mm]</p> <p>1.100 N 1.400 N 4.200 N</p>
<p>N=Newton 1N=kgf 0.1019716</p>			

MATERIALE: Acciaio Inox Aisi 304

TRATTAMENTO:

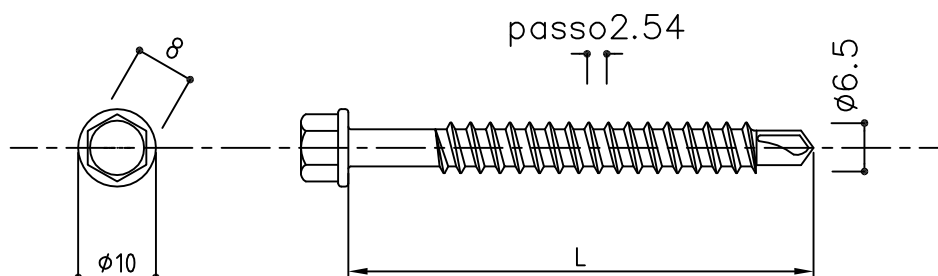
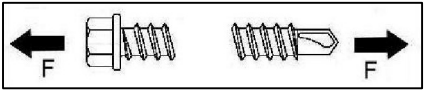
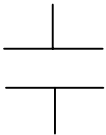
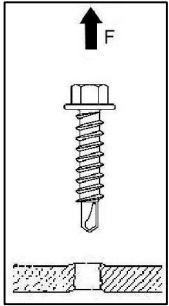
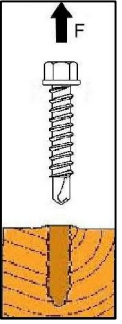
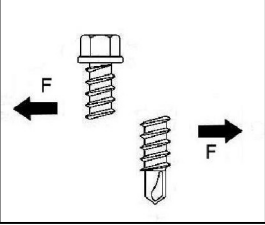
RIVESTIMENTO: Lubrificante di zincatura

SCALA: 1:1

DATA: 08/03/2011



UFFICIO TECNICO
Via dell'Industria,12
20032 Cormano - Mi
TEL. 02/6192097

DESCRIZIONE: **UXW2 6.5 X L**

DESCRIZIONE DETTAGLIATA :

Vite autoperforante INOX punta ridotta.